



DRUM-THIGH SEPARATOR

Delivering Excellence for Processing

- ✓ Unique four-step cutting process
- ✓ Precise anatomic cut
- ✓ Produces fully skinned drumsticks for higher yield and quality

MEYN®



Unique four-step cutting process

The Drum-thigh separator, installed in a 180-degree corner wheel mounted to the overhead conveyor, makes a cut between the drum and thigh joint, producing a drumstick and an anatomical thigh, or a drumstick and a thigh quarter.

The skin and knee cap are then pre-cut by the first blade, giving complete skin coverage on the drumsticks. The thigh is bent open further, creating space for the final blade to separate the drum and the thigh. Drums remain in the shackle, while thighs are released and can be transferred directly to a weighing, grading/batching or packing system.

Product in

Leg quarters

Anatomical legs



Product dropped

2 Thighs with back bone, chops

2 Anatomical thighs



Product out

2 Drumsticks

2 Drumsticks



Highest accuracy

The Drum-thigh separator cuts between the drum and thigh joint to produce a drumstick and anatomical thigh, or drumstick and thigh quarter on a 180° wheel-mounted conveyor.

Next, the skin and kneecap are pre-cut by the first blade, retaining the drumsticks' skin. As the thigh is further opened, a second blade separates the drums and thigh. Drums stay in the shackle while thighs are released with processors having the option to weigh, grade/batch or pack them.

The module is suited for the Physic line.

Delivers
**higher
yield**

**Touch-
free**
bypass



Drum-Thigh Separator

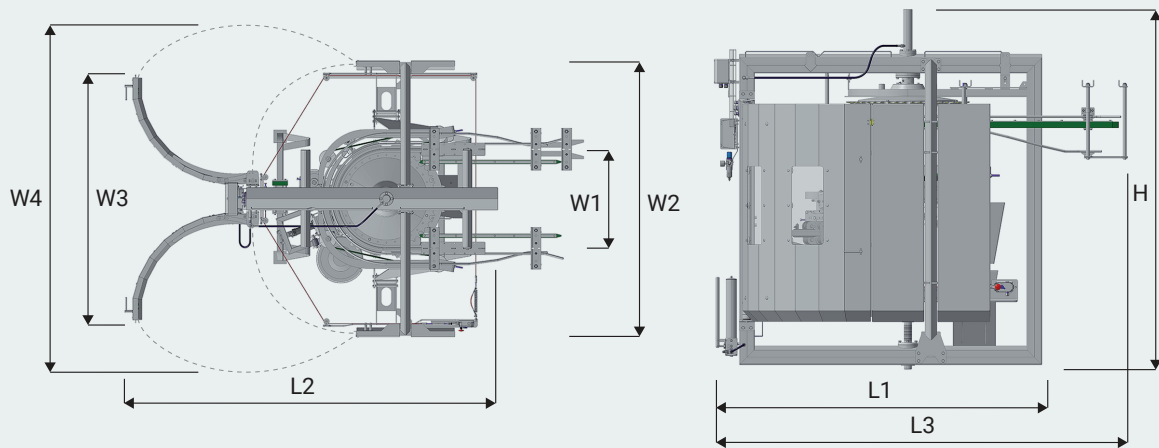

Physic HS Module with by-pass frame

Specifications

		Physic HS Module with by-pass frame
Capacity	BPH	7,500
Griller weight	kg	1,0 - 3,2
Length (L1)	mm	2,150
Length (L2)	mm	2,950
Length (L3)	mm	2,850
Width (W1)	mm	780
Width (W2)	mm	2,200
Width (W3)	mm	1,950
Width (W4)	mm	2,800
Height (H)	mm	2,150
Knife diameter	mm	175
Knife diameter (precut)	mm	350
Knife diameter (main cut)	mm	7,000
Weight	kg	1,000
Electric power installed	kW	2x 0.55



What's your **next move?**

Meyn® Consultancy & Audits

- Enhance your operational efficiency
- Expand your production capabilities
- Identify new market opportunities

Meyn® Academy

- Safeguard investments and enhance profitability
- Specific system and machine training
- Customer specific training options

Meyn® demo's

- Products, services and insights
- Tailormade demo's based on your needs
- Available online in multiple languages

Secure **business continuity**

Meyn Services provides comprehensive support to optimize the performance and reliability of Meyn equipment.

With a strong emphasis on global reach and local presence, Meyn offers various services to ensure customer satisfaction and operational efficiency.

Technical Support

- ✓ Global assistance
- ✓ Corrective and preventive services
- ✓ 24/7 Helpdesk

Maintenance

- ✓ Tailored maintenance
- ✓ Updates and inspections
- ✓ Machine maintenance

Parts

- ✓ OEM replacement parts
- ✓ Always available
- ✓ eProcurement portal



Visit meyn.com

Birds prefer **MEYN**®

**Meyn Food Processing
Technology B.V.**

P.O. Box 16, 1510 AA Oostzaan
The Netherlands
Phone: +31 (0)20 2045 000
Email: sales@meyn.com

Meyn Americas

1000 Evenflo Drive,
Ball Ground, Georgia 30107, USA
Toll Free: 1 888 881 MEYN (6396)
Email: sales.usa@meyn.com

**Find your nearest Meyn
representative:**

www.meyn.com/meyn-worldwide

Version 14-04-2026

The data published, under reservation of all our rights, is to the most recent information at the moment of publication and subject to future modifications. Meyn reserves the right to modify the construction and the execution of its products at any time. No rights can be derived from this publication.

meyn.com