



PRECUTTER WHOLE LEGS

Automates the initial lengthwise cut

- ✓ Automatically precuts anatomical legs
- ✓ Minimal bone and cartilage contamination from knee
- ✓ Saves 3 FTE per 4,200 legs/hr

MEYN[®]

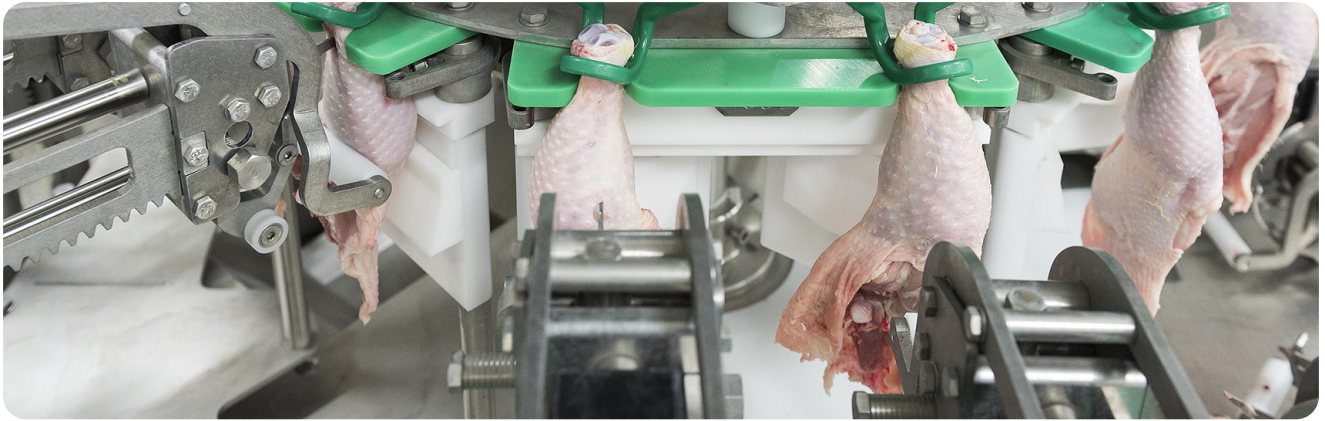

Automatically precuts anatomical legs

The Precutter cuts lengthwise on the anatomical leg then laterally along the drum, knee and thigh bone.

The module operates on a 180° carousel which can be integrated in the Physic HS cut up line. It automates the initial lengthwise cut required for whole leg deboning.

“The module produces a cut along the whole leg (J-cut), to allow whole leg deboning. Or a cut along the drumstick to allow in-line drum- and thigh deboning. The cut without causing damage will guarantee maximum yield and least amount of bones in the fillet.”

Product in
Whole anatomical leg



Product out
Whole leg with lateral cut



I-Cut
Obligatory



J-Cut
Extra feature

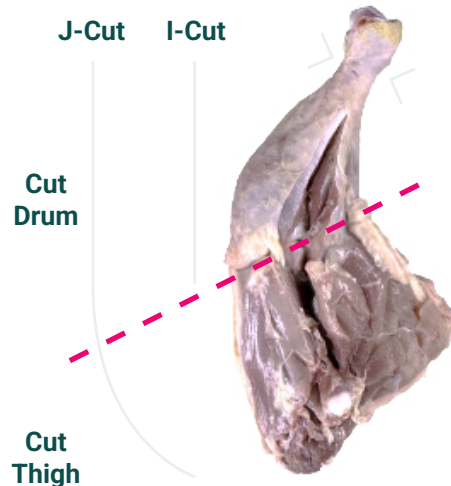

Precutter Whole Legs

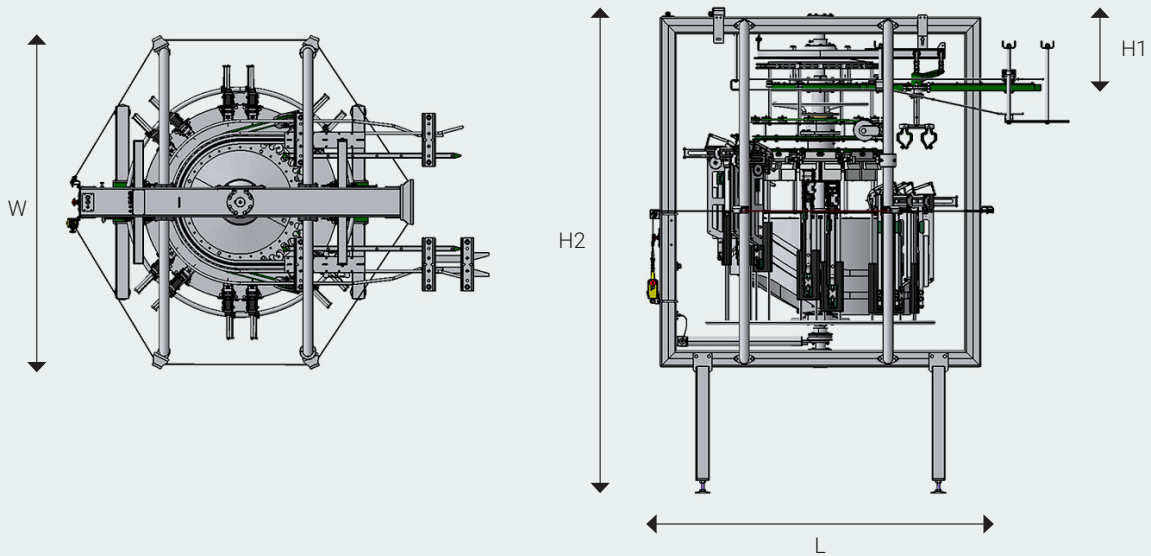

Specifications

Capacity	Legs/hr	15,000
Griller weight	kg	1.0 - 3.2
Length (L)	mm	2,100
Width (W)	mm	2,100
Height (H)	mm	320
Height (H)	mm	2,250
Weight (W)	kg	1,400

Touch-free
bypass

Save up to
3 FTE
per 4,200
legs/hr



Meyn® PRECUTTER WHOLE LEGS



What's your **next** **move?**

Meyn® Consultancy & Audits

- Enhance your operational efficiency
- Expand your production capabilities
- Identify new market opportunities

Meyn® Academy

- Safeguard investments and enhance profitability
- Specific system and machine training
- Customer specific training options

Meyn® demo's

- Products, services and insights
- Tailormade demo's based on your needs
- Available online in multiple languages

Secure **business** **continuity**

Meyn Services provides comprehensive support to optimize the performance and reliability of Meyn equipment.

With a strong emphasis on global reach and local presence, Meyn offers various services to ensure customer satisfaction and operational efficiency.

Technical Support

- ✓ Global assistance
- ✓ Corrective and preventive services
- ✓ 24/7 Helpdesk

Maintenance

- ✓ Tailored maintenance
- ✓ Updates and inspections
- ✓ Machine maintenance

Parts

- ✓ OEM replacement parts
- ✓ Always available
- ✓ eProcurement portal



Visit meyn.com

Birds prefer **MEYN**®

**Meyn Food Processing
Technology B.V.**

P.O. Box 16, 1510 AA Oostzaan
The Netherlands
Phone: +31 (0)20 2045 000
Email: sales@meyn.com

Meyn Americas

1000 Evenflo Drive,
Ball Ground, Georgia 30107, USA
Toll Free: 1 888 881 MEYN (6396)
Email: sales.usa@meyn.com

**Find your nearest Meyn
representative:**

www.meyn.com/meyn-worldwide

Version 14-04-2026

The data published, under reservation of all our rights, is to the most recent information at the moment of publication and subject to future modifications. Meyn reserves the right to modify the construction and the execution of its products at any time. No rights can be derived from this publication.

meyn.com