

maestro

M4.0 PRO SERIES

INSIDE/OUTSIDE WASHER



# The clean finish to evisceration

- ✓ The Meyn washing strategy ensures a thorough washing result
- ✓ Available with options to address your specific challenges
- ✓ Highest uptime in the market

**MEYN**®



## Meyn® Inside/Outside Washer

# Closing the line with clean accuracy

The Inside/Outside Washer is strategically positioned in a 240° curve on the overhead conveyor, typically as the final machine in the evisceration line. Depending on your needs, the washer can be configured with either a brush type (Circlean) or spinning nozzle, both providing thorough internal carcass cleaning.



## Spinning Nozzle

Carcasses are fed with their backs towards the center, guided by a static guide, and positioned by a centering bracket. Inside washing is performed by a spinning nozzle entering the abdominal cavity, with double stroke action enhancing the effect. Outside washing is handled by dedicated nozzles on the breast and back. Carcasses pass through a final rinsing unit upon exiting, ensuring thorough cleaning



## Brush type (Circlean)

The brush-type model excels in water usage, performance, and durability. Its robust stainless-steel construction and proven gear cam design ensure long maintenance intervals. The rotating brush head cleans the inside of the carcass, while fixed nozzles clean the outside. FDA-approved blue strings effectively remove dirt, even under leaf fat, and are easily replaceable. The double stroke action ensures thorough cleaning.

## Specifications Meyn® Maestro M4.0 Pro Series

Live weight	Kg [lbs.]	Standard broilers: 1,6 – 3,6 [3.5 – 8] Small birds: 0,5 – 1,8 [1.1 – 3.7]*	Big birds: 2,5 – 5,5 [5.5 – 12]
Shackle pitch	inch	6"	8"
Model		20 units	15 units
Capacity	bph [bpm]	13.500 [225]	10.500 [175]
Length (L1)	mm	2.620	2.620
	[inch]	[103.2]	[103.2]
(L2)	mm	3.001	3.001
	[inch]	[118.2]	[118.2]
Width (W1)	mm	1.880	1.880
	[inch]	[74.0]	[74.0]
(W2)	mm	3.246	3.246
	[inch]	[127.8]	[127.8]
Height (H)	mm	2.766	2.766
	[inch]	[108.9]	[108.9]

\*only available in Spinning Nozzle

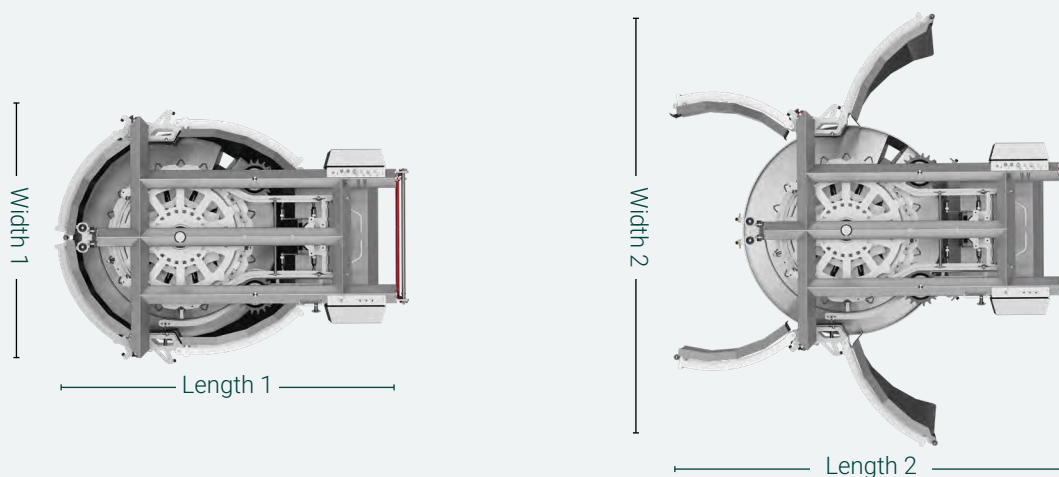

## Utility connections Meyn® Inside/Outside Washer

<b>Water connection 1</b>	BSP	G1/2"
Pressure	bar	10
Flow	l/min	max. 100
<b>Air connection</b>	BSP	G1/4"
Pressure	Bar	8
Flow	nl/min	1.000 (consumption negligible)
<b>Drain connection</b>	DIN Flange D=158mm T=6mm	

## Performance

# Optimized yield, effortless cleaning

The improved free positioning system allows for a wide weight range to be processed within one machine setting. In combination with the 240° curve, which creates more processing time per bird, a high yield for every step in the process is guaranteed.

Experience effortless cleaning with our newly designed frame with integrated piping and wiring, featuring open access processing units, for a sleek and functional design.

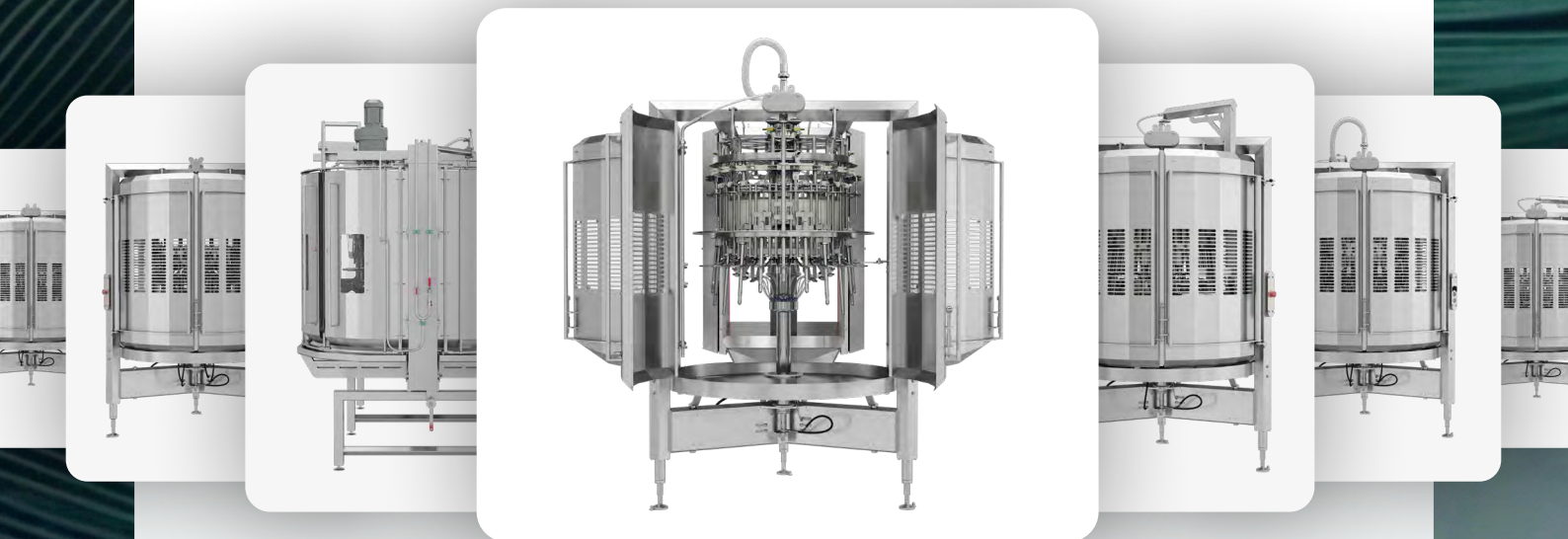

## Safety

# Enhanced safety and efficiency

Meyn is dedicated in providing safe working environments to our customers. The safety concept of the Maestro M4.0 Pro Series is designed around the 'Door open = Line off' principle. All settings are adjustable from the outside, or automatically, while the line is running. The modules can be completely cleaned with the line off. Increased safety without operational limitations.

maestro



Guaranteed  
**high  
yield**

Effortless  
**cleaning**

Save up to  
**50%**  
maintenance  
time

**Maintenance**

## Faster, easier **maintenance**

The Tri-pod frame design ensures comprehensive accessibility for effortless maintenance. With split units and a modular shaft design, maintenance time is slashed by up to 50%. Additionally, the Maestro M4.0 Pro modules share most of their wear parts, significantly lowering the need for extensive safety stock.

## Options

# Fully adjustable to your business needs

### ✔ **Flock Control**

Dealing with the machine settings for different flocks can be a challenge. With this option the settings of the equipment can be stored and recalled on the satellite panel. Based on breed and average live weight. The settings of all Maestro M4.0 Pro Series equipment in line are changed with one push of a button. Now everyone can run the line at high efficiency.

### ✔ **Water Saving**

Save up to 15% of water. With this option we track the birds through your production line and automatically turn the water supply on and off.

No birds = no water.

### ✔ **Unit Cleaning\***

Keep your performance stable during a shift by automatically applying medium pressure water to rinse the processing units when there are no birds in the machine. Keep it clean, keep it running.

### ✔ **Water Air Mix (Undine®)**

Improve the cleaning result and reduce the water consumption by using a mixture of water and air. The pressurized air increases the speed of the water and breaks it down to smaller droplets. The sophisticated mixing chambers and special nozzles ensure an optimal cleaning result.

### ✔ **Pressure Pump Kit (10 bar)**

The I/O Washer requires a water pressure of 10 bar. With this pump kit the standard water pressure is upgraded and monitored by a pressure sensor. The required pressure can be set, based on the desired cleaning result, from which water consumption can be reduced to minimally required levels. In combination with the water saving option, this pump also supplies a rinse cycle to the Final Inspection vacuum nozzles.

\* Only available in combination with the water saving option. Requires a connection of 30 bar water (30-40 °C, G3/8", 11.2 l/min). A pressure pump kit for the line is available to boost the standard water pressure.



# What's your **next move?**

## **Meyn® Consultancy & Audits**

- Enhance your operational efficiency
- Expand your production capabilities
- Identify new market opportunities

## **Meyn® Academy**

- Safeguard investments and enhance profitability
- Specific system and machine training
- Customer specific training options

## **Meyn® demo's**

- Products, services and insights
- Tailormade demo's based on your needs
- Available online in multiple languages

## Secure **business continuity**

Meyn Services provides comprehensive support to optimize the performance and reliability of Meyn equipment.

With a strong emphasis on global reach and local presence, Meyn offers various services to ensure customer satisfaction and operational efficiency.

### **Technical Support**

- ✓ Global assistance
- ✓ Corrective and preventive services
- ✓ 24/7 Helpdesk

### **Maintenance**

- ✓ Tailored maintenance
- ✓ Updates and inspections
- ✓ Machine maintenance

### **Parts**

- ✓ OEM replacement parts
- ✓ Always available
- ✓ eProcurement portal



Visit [meyn.com](https://meyn.com)

Birds prefer **MEYN**®

**Meyn Food Processing  
Technology B.V.**

P.O. Box 16, 1510 AA Oostzaan  
The Netherlands  
Phone: +31 (0)20 2045 000  
Email: [sales@meyn.com](mailto:sales@meyn.com)

**Meyn America LLC**

1000 Evenflo Drive,  
Ball Ground, Georgia 30107, USA  
Toll Free: 1 888 881 MEYN (6396)  
Email: [sales.usa@meyn.com](mailto:sales.usa@meyn.com)

**Find your nearest Meyn  
representative:**

[www.meyn.com/meyn-worldwide](https://www.meyn.com/meyn-worldwide)

Version 01-06-2026

The data published, under reservation of all our rights, is to the most recent information at the moment of publication and subject to future modifications. Meyn reserves the right to modify the construction and the execution of its products at any time. No rights can be derived from this publication.

**[meyn.com](https://meyn.com)**