

maestro

M4.0 PRO SERIES

NECK BREAKER

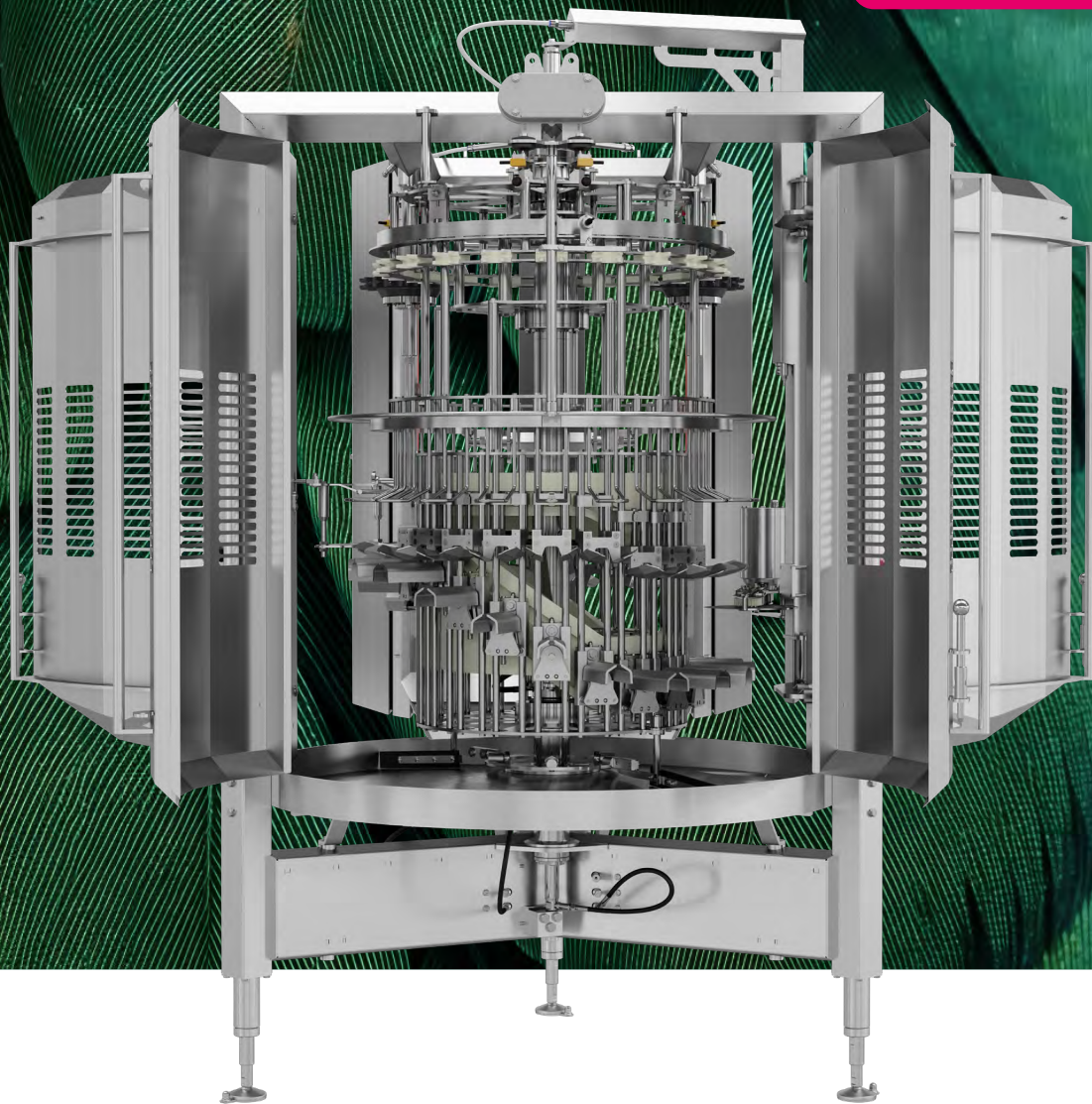

# Enhancing efficiency and **product quality**

- ✓ Keeps the neck and neck skin fully intact
- ✓ Available with options to address your specific challenges
- ✓ Highest uptime in the market

**MEYN**®



## Meyn® Neck Breaker

# Precise alignment, prevents damage

The Neck Breaker is strategically positioned in a 240° curve on the overhead conveyor, typically right after the crop removal stage. Birds are fed breast-side towards the machine's center. Static guides, along with a centering bracket between the legs, ensure precise alignment.

## Enhancing efficiency

An under unit deploys two shoulder supports to lift each bird, accommodating size variations. Simultaneously, the wings are lifted to prevent damage or removal during the neck-breaking process. Once correctly positioned, the curve-

controlled breaking unit efficiently breaks the neck. The neck length can be adjusted to meet specific requirements. This setup ensures consistent and precise processing, enhancing overall efficiency and product quality

## Specifications Meyn® Maestro M4.0 Pro Series

Live weight	Kg [lbs.]	Standard broilers: 1,6 – 3,6 [3.5 – 8] Small birds: 0,5 – 1,8 [1.1 – 3.7]	Big birds: 2,5 – 5,5 [5.5 – 12]
Shackle pitch	inch	6"	8"
Model		20 units	15 units
Capacity	bph [bpm]	13.500 [225]	10.500 [175]
Length (L1)	mm	2.620	2.620
	[inch]	[103.2]	[103.2]
(L2)	mm	3.001	3.001
	[inch]	[118.2]	[118.2]
Width (W1)	mm	1.880	1.880
	[inch]	[74.0]	[74.0]
(W2)	mm	3.246	3.246
	[inch]	[127.8]	[127.8]
Height (H)	mm	2.766	2.766
	[inch]	[108.9]	[108.9]

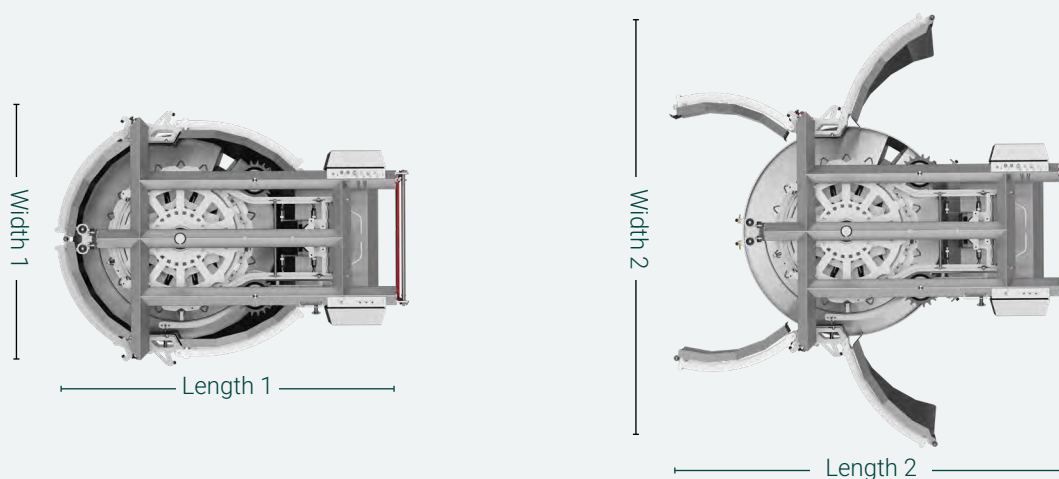

## Utility connections Meyn® Neck Breaker

<b>Water connection 1</b>	BSP	G1/2"
Pressure	bar	3
Flow	l/min	6,5
<b>Air connection</b>	BSP	G1/4"
Pressure	Bar	8
Flow	nl/min	1.000 (consumption negligible)
<b>Electrical connection</b>	kW	0,25
<b>Drain connection</b>	DIN Flange D=158mm T=6mm	

## Performance

# Optimized yield, effortless cleaning

The improved free positioning system allows for a wide weight range to be processed within one machine setting. In combination with the 240° curve, which creates more processing time per bird, a high yield for every step in the process is guaranteed.

Experience effortless cleaning with our newly designed frame with integrated piping and wiring, featuring open access processing units, for a sleek and functional design.

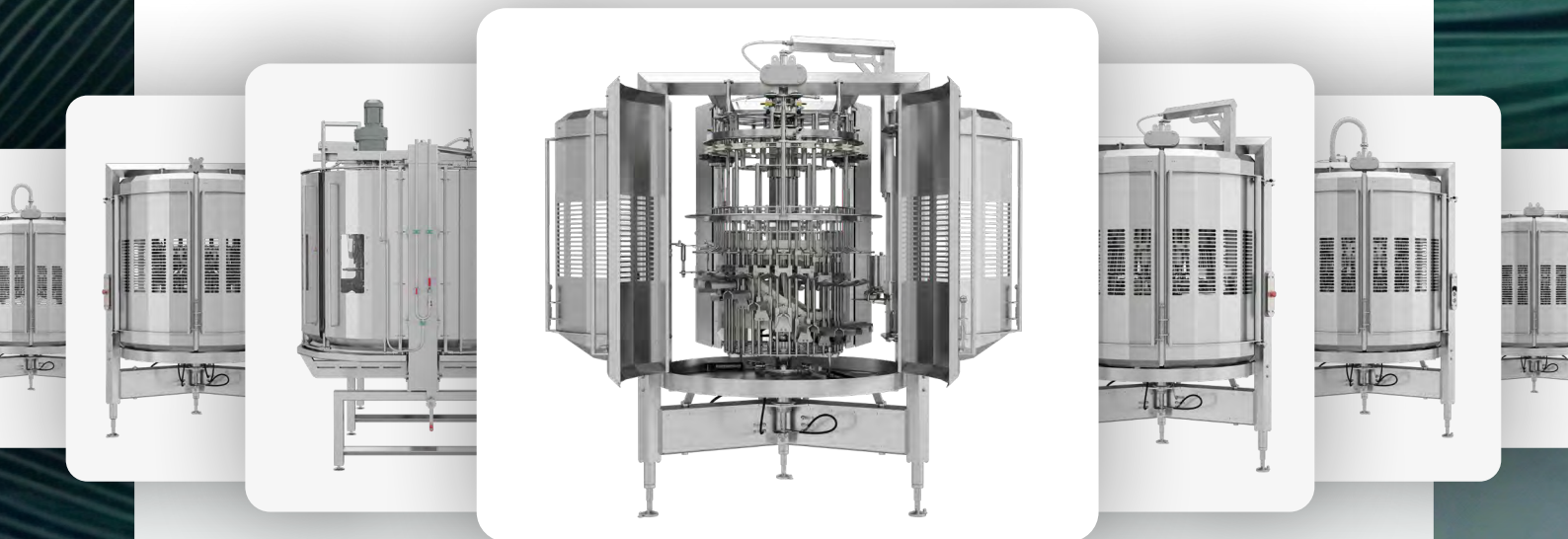

## Safety

# Enhanced safety and efficiency

Meyn is dedicated in providing safe working environments to our customers. The safety concept of the Maestro M4.0 Pro Series is designed around the 'Door open = Line off' principle. All settings are adjustable from the outside, or automatically, while the line is running. The modules can be completely cleaned with the line off. Increased safety without operational limitations.



Guaranteed  
**high  
yield**

Effortless  
**cleaning**

Save up to  
**50%**  
maintenance  
time

### Maintenance

## Faster, easier maintenance

The Tri-pod frame design ensures comprehensive accessibility for effortless maintenance. With split units and a modular shaft design, maintenance time is slashed by up to 50%. Additionally, the Maestro M4.0 Pro modules share most of their wear parts, significantly lowering the need for extensive safety stock.

## Options

# Fully adjustable to your business needs

### ✓ **Flock Control**

Dealing with the machine settings for different flocks can be a challenge. With this option the settings of the equipment can be stored and recalled on the satellite panel. Based on breed and average live weight. The settings of all Maestro M4.0 Pro Series equipment in line are changed with one push of a button. Now everyone can run the line at high efficiency.

### ✓ **Water Saving**

Save up to 15% of water. With this option we track the birds through your production line and automatically turn the water supply on and off.

No birds = no water.

### ✓ **Unit Cleaning\***

Keep your performance stable during a shift by automatically applying medium pressure water to rinse the processing units when there are no birds in the machine. Keep it clean, keep it running.

\* Only available in combination with the water saving option. Requires a connection of 30 bar water (30-40 °C, G3/8", 11.2 l/min). A pressure pump kit for the line is available to boost the standard water pressure.



# What's your **next move?**

## **Meyn® Consultancy & Audits**

- Enhance your operational efficiency
- Expand your production capabilities
- Identify new market opportunities

## **Meyn® Academy**

- Safeguard investments and enhance profitability
- Specific system and machine training
- Customer specific training options

## **Meyn® demo's**

- Products, services and insights
- Tailormade demo's based on your needs
- Available online in multiple languages

## Secure **business continuity**

Meyn Services provides comprehensive support to optimize the performance and reliability of Meyn equipment.

With a strong emphasis on global reach and local presence, Meyn offers various services to ensure customer satisfaction and operational efficiency.

### **Technical Support**

- ✓ Global assistance
- ✓ Corrective and preventive services
- ✓ 24/7 Helpdesk

### **Maintenance**

- ✓ Tailored maintenance
- ✓ Updates and inspections
- ✓ Machine maintenance

### **Parts**

- ✓ OEM replacement parts
- ✓ Always available
- ✓ eProcurement portal



Visit [meyn.com](https://meyn.com)

Birds prefer **MEYN**®

**Meyn Food Processing  
Technology B.V.**

P.O. Box 16, 1510 AA Oostzaan  
The Netherlands  
Phone: +31 (0)20 2045 000  
Email: [sales@meyn.com](mailto:sales@meyn.com)

**Meyn America LLC**

1000 Evenflo Drive,  
Ball Ground, Georgia 30107, USA  
Toll Free: 1 888 881 MEYN (6396)  
Email: [sales.usa@meyn.com](mailto:sales.usa@meyn.com)

**Find your nearest Meyn  
representative:**

[www.meyn.com/meyn-worldwide](https://www.meyn.com/meyn-worldwide)

Version 01-06-2026

The data published, under reservation of all our rights, is to the most recent information at the moment of publication and subject to future modifications. Meyn reserves the right to modify the construction and the execution of its products at any time. No rights can be derived from this publication.

**[meyn.com](https://meyn.com)**