

maestro

M4.0 PRO SERIES

VENT CUTTER

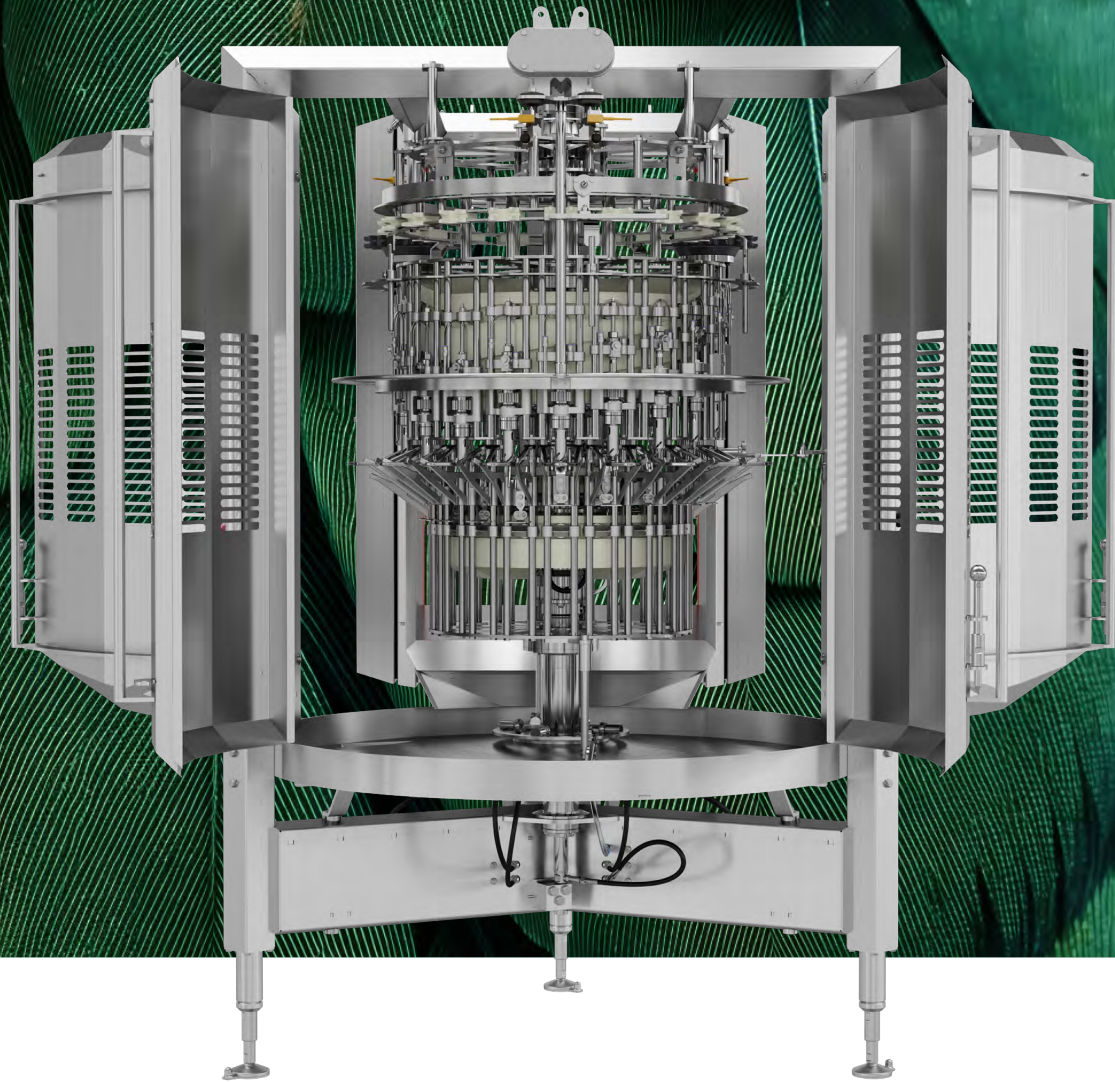

Optimized **vent cutting** for **efficient processing**

- ✓ Very precise vent cutting result with a minimal of intestinal damage
- ✓ Available with options to address your specific challenges
- ✓ Highest uptime in the market

MEYN®



Meyn® Vent Cutter

Innovative vent cutting for higher efficiency

The Vent Cutter is strategically placed in the 240-degree curve of the overhead conveyor, usually as the first machine in the EV line. Birds, bled and defeathered, are guided into the machine with their backs toward its center. Static infeed guides position the birds into the processing units. Two-sided supports lift and center each bird using a bracket.

Precise and safe processing

The drilling section then lowers, with a cone entering the vent and a knife cutting the skin. There are different sizes of knives available, depending on the weight range. A patented bushing mechanism prevents the knife from damaging the intestines. After deeper cutting, the vent is clamped and the bird is lowered,

pulling the intestines out over about 100 mm. The vent is then positioned over the bird's back before release. After each cycle, the drill unit is high-pressure cleaned from the inside, ensuring a clean centering cone before the next processing unit starts.

Specifications Meyn® Maestro M4.0 Pro Series

Live weight	Kg [lbs.]	Standard broilers: 1,6 – 3,6 [3.5 – 8] Small birds: 0,5 – 1,8 [1.1 – 3.7]	Big birds: 2,5 – 5,5 [5.5 – 12]
Shackle pitch	inch	6"	8"
Model		20 units	15 units
Capacity	bph [bpm]	13.500 [225]	10.500 [175]
Length (L1)	mm	2.620	2.620
	[inch]	[103.2]	[103.2]
(L2)	mm	3.001	3.001
	[inch]	[118.2]	[118.2]
Width (W1)	mm	1.880	1.880
	[inch]	[74.0]	[74.0]
(W2)	mm	3.246	3.246
	[inch]	[127.8]	[127.8]
Height (H)	mm	2.766	2.766
	[inch]	[108.9]	[108.9]

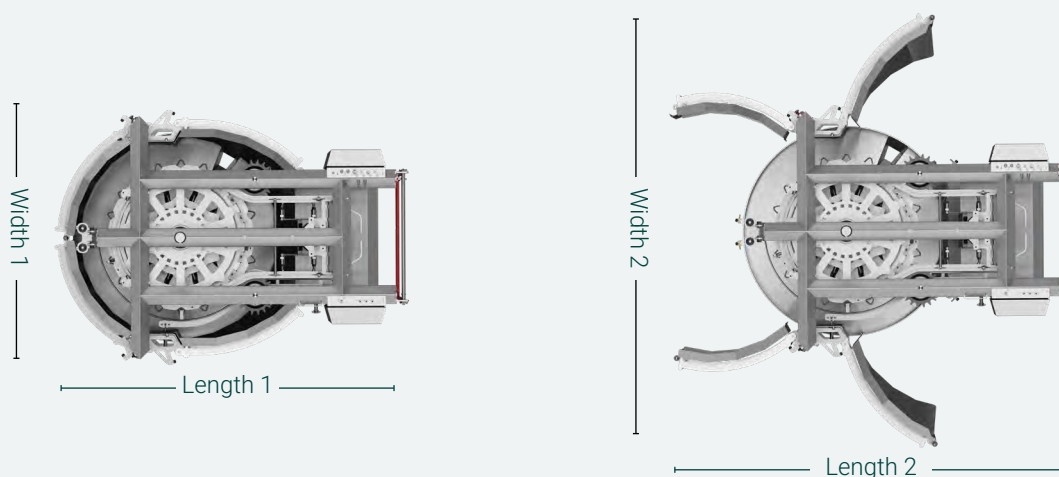

Utility connections Meyn® Vent Cutter

Water connection 1	BSP	G1/2"
Pressure	bar	3
Flow	l/min	15.7
Water connection 2	BSP	G3/8"
Pressure	bar	100
Flow	l/min	10.2
Air connection	BSP	G1/4"
Pressure	Bar	8
Flow	nl/min	1.000 (consumption negligible)
Drain connection	DIN Flange D=158mm T=6mm	

Performance

Optimized yield, effortless cleaning

The improved free positioning system allows for a wide weight range to be processed within one machine setting. In combination with the 240° curve, which creates more processing time per bird, a high yield for every step in the process is guaranteed.

Experience effortless cleaning with our newly designed frame with integrated piping and wiring, featuring open access processing units, for a sleek and functional design.

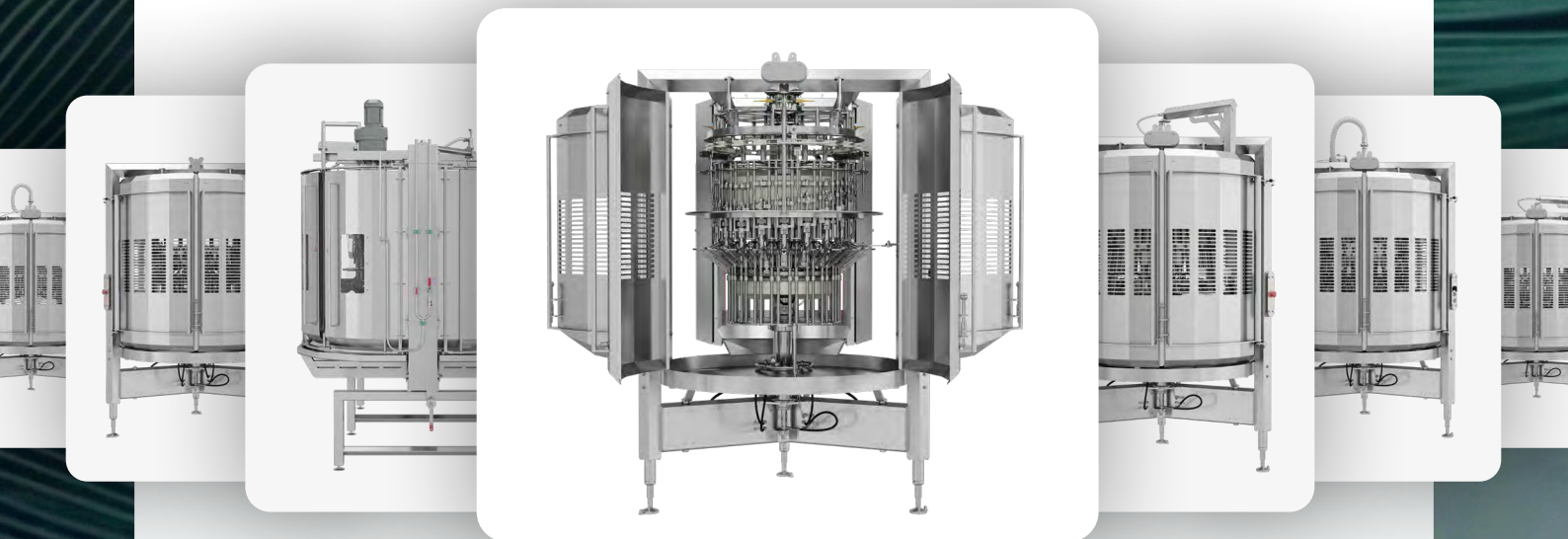

Safety

Enhanced safety and efficiency

Meyn is dedicated in providing safe working environments to our customers. The safety concept of the Maestro M4.0 Pro Series is designed around the 'Door open = Line off' principle. All settings are adjustable from the outside, or automatically, while the line is running. The modules can be completely cleaned with the line off. Increased safety without operational limitations.



Guaranteed
**high
yield**

Effortless
cleaning

Save up to
50%
maintenance
time

Maintenance

Faster, easier maintenance

The Tri-pod frame design ensures comprehensive accessibility for effortless maintenance. With split units and a modular shaft design, maintenance time is slashed by up to 50%. Additionally, the Maestro M4.0 Pro modules share most of their wear parts, significantly lowering the need for extensive safety stock.

Options

Fully adjustable to your business needs

✓ **Flock Control**

Dealing with the machine settings for different flocks can be a challenge. With this option the settings of the equipment can be stored and recalled on the satellite panel. Based on breed and average live weight. The settings of all Maestro M4.0 Pro Series equipment in line are changed with one push of a button. Now everyone can run the line at high efficiency.

✓ **Water Saving**

Save up to 15% of water. With this option we track the birds through your production line and automatically turn the water supply on and off.

No birds = no water.

✓ **Unit Cleaning***

Keep your performance stable during a shift by automatically applying medium pressure water to rinse the processing units when there are no birds in the machine. Keep it clean, keep it running.

✓ **Vacuum on Vent Knives**

Adds suction to the vent knife cones to optimize the positioning of the cut and helps to eliminate liquid fecal material leaking on the back of the carcass.

Requires a connection of -0,6 bar, G1 ½"

✓ **High Pressure Pump Kit**

Boost the standard water pressure up to 80-120 bar, required for cleaning the knives and cones after each cycle.

* Only available in combination with the water saving option. Requires a connection of 30 bar water (30-40 °C, G3/8", 11.2 l/min). A pressure pump kit for the line is available to boost the standard water pressure.



What's your **next move?**

Meyn® Consultancy & Audits

- Enhance your operational efficiency
- Expand your production capabilities
- Identify new market opportunities

Meyn® Academy

- Safeguard investments and enhance profitability
- Specific system and machine training
- Customer specific training options

Meyn® demo's

- Products, services and insights
- Tailormade demo's based on your needs
- Available online in multiple languages

Secure **business continuity**

Meyn Services provides comprehensive support to optimize the performance and reliability of Meyn equipment.

With a strong emphasis on global reach and local presence, Meyn offers various services to ensure customer satisfaction and operational efficiency.

Technical Support

- ✓ Global assistance
- ✓ Corrective and preventive services
- ✓ 24/7 Helpdesk

Maintenance

- ✓ Tailored maintenance
- ✓ Updates and inspections
- ✓ Machine maintenance

Parts

- ✓ OEM replacement parts
- ✓ Always available
- ✓ eProcurement portal



Visit meyn.com

Birds prefer **MEYN**®

**Meyn Food Processing
Technology B.V.**

P.O. Box 16, 1510 AA Oostzaan
The Netherlands
Phone: +31 (0)20 2045 000
Email: sales@meyn.com

Meyn America LLC

1000 Evenflo Drive,
Ball Ground, Georgia 30107, USA
Toll Free: 1 888 881 MEYN (6396)
Email: sales.usa@meyn.com

**Find your nearest Meyn
representative:**

www.meyn.com/meyn-worldwide

Version 01-06-2026

The data published, under reservation of all our rights, is to the most recent information at the moment of publication and subject to future modifications. Meyn reserves the right to modify the construction and the execution of its products at any time. No rights can be derived from this publication.

meyn.com